

ASSEMBLY AND INSTALLATION INSTRUCTIONS

T0565

WARNING: Turn off the main power at circuit breaker before installing fixture.
AVERTISSEMENT: Coupez la source d'alimentation principale au panneau central de disjoncteurs avant d'installer le luminaire.

NOTE: 1. Before installing, consult local electrical codes for wiring and grounding requirements.
2. READ AND SAVE THESE INSTRUCTIONS.

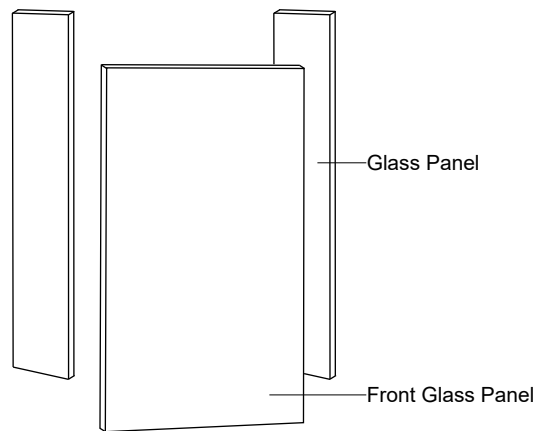
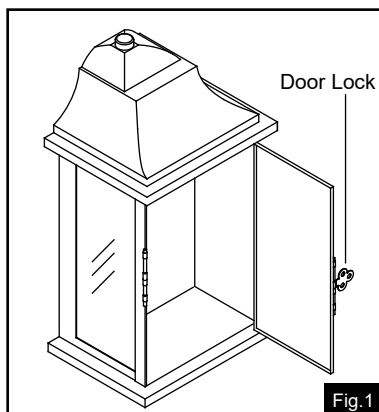
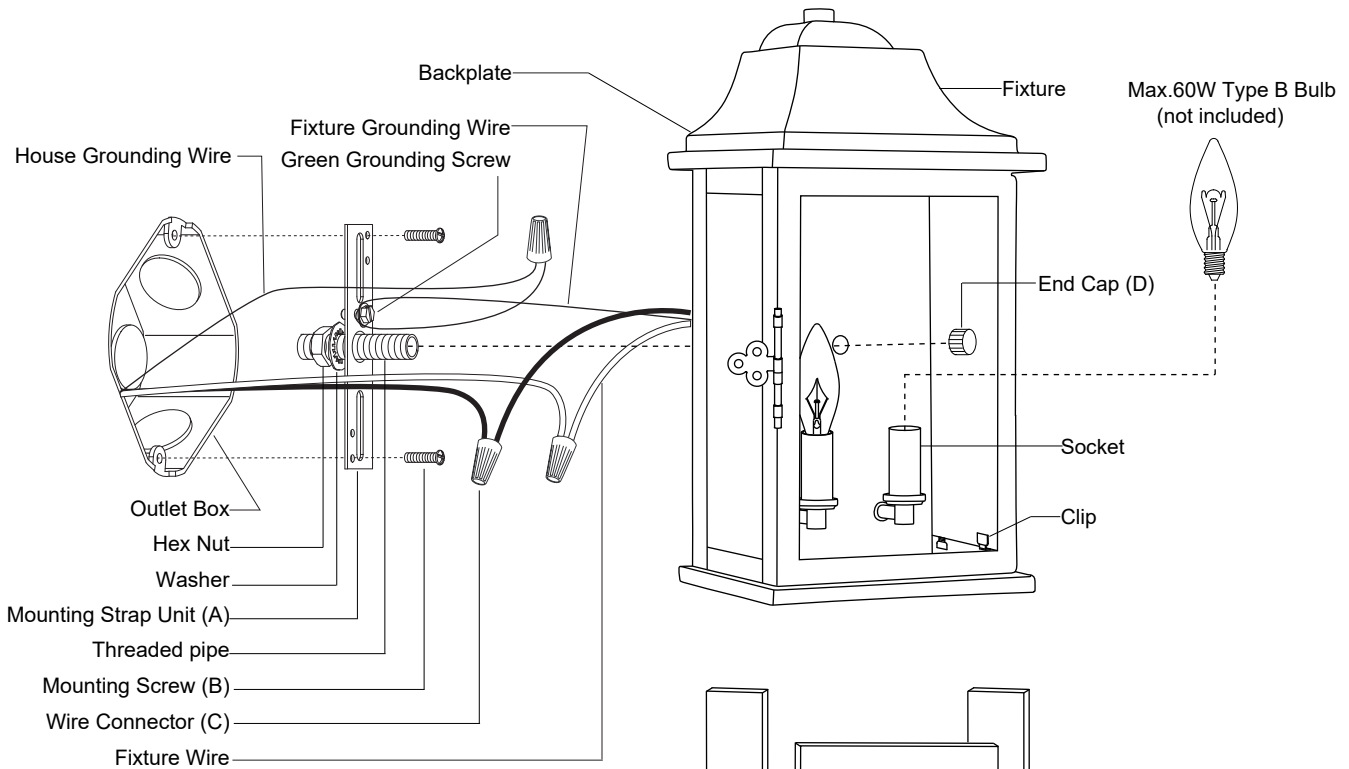
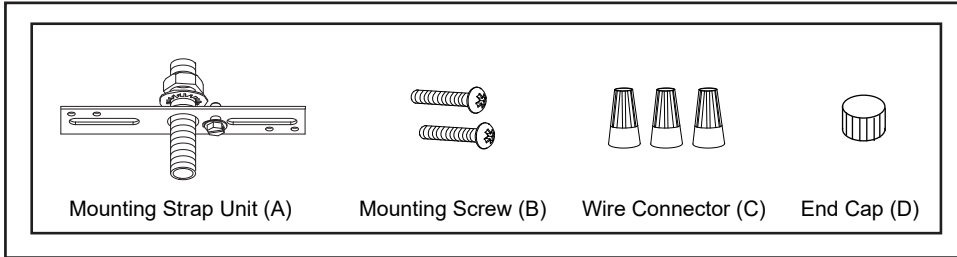

Installation Steps

Turn off the power at fuse or circuit box

1. Attach the mounting strap unit (A) to the outlet box by using two mounting screws (B).
2. Pull out the source wires from the outlet box. Make wire connections using wire connectors (C) as follows:
 - Connect the hot wire (usually black insulation) from the fixture to the black wire from the power source.
 - Connect the neutral wire (usually white insulation) from the fixture to the white wire from the power source.
 - Attach the fixture grounding wire (usually green insulation or bare wire) to the mounting strap unit (A) with the green grounding screw. Then, depending on local code connect it to the house grounding wire with the wire connector (C).Carefully put all of the wires back into the outlet box.

3. Attach the fixture to the mounting strap unit (A) by inserting the threaded pipe, then secure it with the end cap (D).
4. Make the top of the fixture upward, gently place three glass panels into the frame, then press the clips to secure the glass panels and front glass panel. (See Fig.2)
5. Install bulbs (not included). Check relamping label at socket area or packaging for maximum wattage allowed.
6. Attach the door lock secure the fixture.

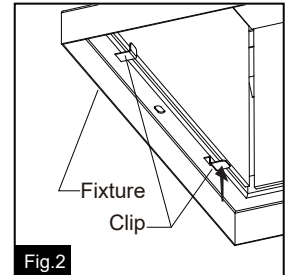

Turn on the power at fuse or circuit box

The following parts are available for re-order if damaged or missing.

Spare Parts List:

Mounting Strap Unit (A) Mounting Screw (B) Wire Connector (C) End Cap (D)

Front Glass Panel X1 Glass Panel X2

10141CS

Mounting Hardware 6189MM (1SET)

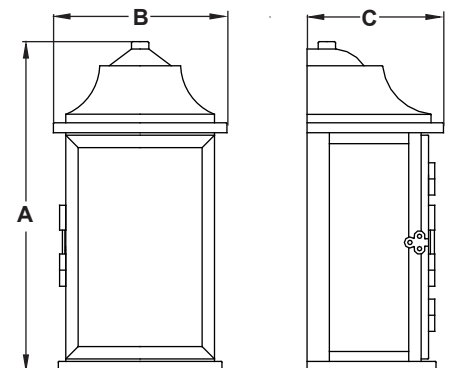

A: 13"

B: 7-1/2"

C: 4-1/4"

1 Year Warranty

Vaxcel warrants all of our products against defects in workmanship and finishes for one year following the date of shipment.

Exclusions: This warranty does not include the failure of products from extreme acts of nature; environmental conditions not suited for the products intended use; operation in temperatures outside of the range specified in the instruction manual; usage with improper power supply, power surges or dips. For coastal locations, some corrosion is considered normal for the environment.

Vaxcel reserves the right to repair, replace or issue a credit for any properly installed product, provided it is returned per RMA instruction. This warranty is limited to the cost of the product only and does not extend to transportation, installation or replacement costs.

How can warranty service be obtained?

info@vaxcel.com

1-800-482-9235