

# ASSEMBLY AND INSTALLATION INSTRUCTIONS

P0354

**WARNING:** TO AVOID RISK OF ELECTRICAL SHOCK, BE SURE TO SHUT OFF POWER WHILE INSTALLING OR SERVICING THIS FIXTURE.

**NOTES:** 1. Before installing, consult local electrical codes for wiring and grounding requirements.  
2. READ AND SAVE THIS INSTRUCTION.

## Hardware Package(inculded):

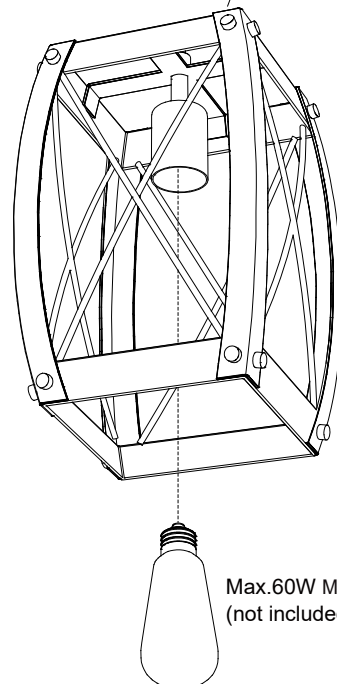
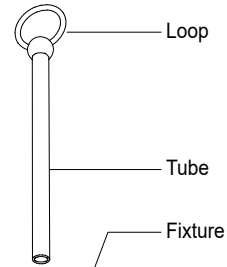
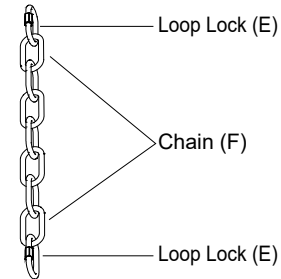
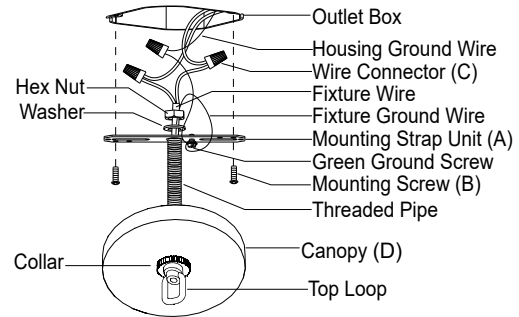
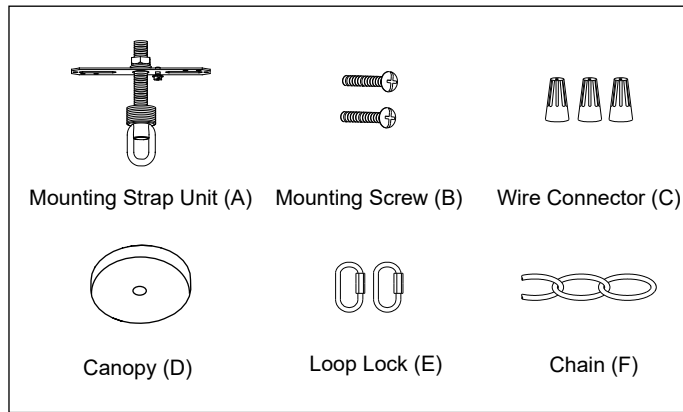

Max.60W Medium Base bulb  
(not included)

## Installation Steps

Turn off the power at fuse or circuit box.

1. Attach the mounting strap unit (A) to the outlet box using two mounting screws (B).
2. Choose the length of the chain (F) you need, then weave the fixture wire and the fixture ground wire through the chain (F), collar and canopy (D).
3. Screw the tube to the fixture.
4. Connect one end of the chain (F) with the loop by using a loop lock (E).
5. Connect the other end of the chain (F) with the top loop by using another loop lock (E).
6. Thread the fixture wire and fixture ground wire through the top loop, threaded pipe and mounting strap unit (A).
7. Pull out the outlet wires and house ground wire from the outlet box. Make wire connections using the wire connectors (C):
  - The smooth wire (marked) from the fixture to the black wire from the power source.
  - The ridged wire (unmarked) from the fixture to the white wire from the power source.
  - Attach the fixture ground wire to the mounting strap unit (A) with the green ground screw. Then connect it to the house ground wire with a wire connector (C).
 Carefully put the wires back into the outlet box.





8. Attach the canopy (D) to the mounting strap unit (A) by inserting the top loop.

9. Install the bulb (not included). See relamping label at socket area or packaging for maximum wattage allowed.

**Turn on the power at fuse or circuit box.**

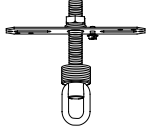
The following parts are available for re-order if damaged or missing.

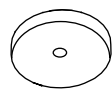
**Spare Parts List:**

					
Mounting Strap Unit (A)	Mounting Screw (B)	Wire Connector (C)	Canopy (D)	Loop Lock (E)	Chain (F)

↓  
Assembly Kit  
6336MM (1 SET)

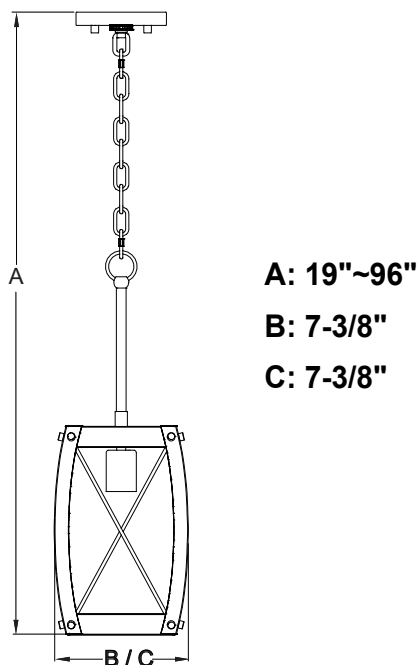

### 1 Year Warranty

Vaxcel warrants all of our products against defects in workmanship and finishes for one year following the date of shipment.

*Exclusions: This warranty does not include the failure of products from extreme acts of nature; environmental conditions not suited for the products intended use; operation in temperatures outside of the range specified in the instruction manual; usage with improper power supply, power surges or dips. For coastal locations, some corrosion is considered normal for the environment.*

*Vaxcel reserves the right to repair, replace or issue a credit for any properly installed product, provided it is returned per RMA instruction. This warranty is limited to the cost of the product only and does not extend to transportation, installation or replacement costs.*

How can warranty service be obtained?  
info@vaxcel.com  
1-800-482-9235