

ASSEMBLY AND INSTALLATION INSTRUCTIONS

P0219

WARNING: TO AVOID RISK OF ELECTRICAL SHOCK, BE SURE TO SHUT OFF POWER BEFORE INSTALLING OR SERVICING THIS FIXTURE.

NOTES: 1. Before installing, consult local electrical codes for wiring and grounding requirements.
2. READ AND SAVE THESE INSTRUCTIONS.

Hardware Package (included):

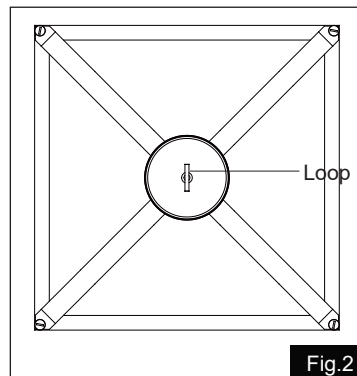
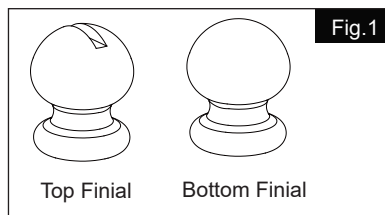
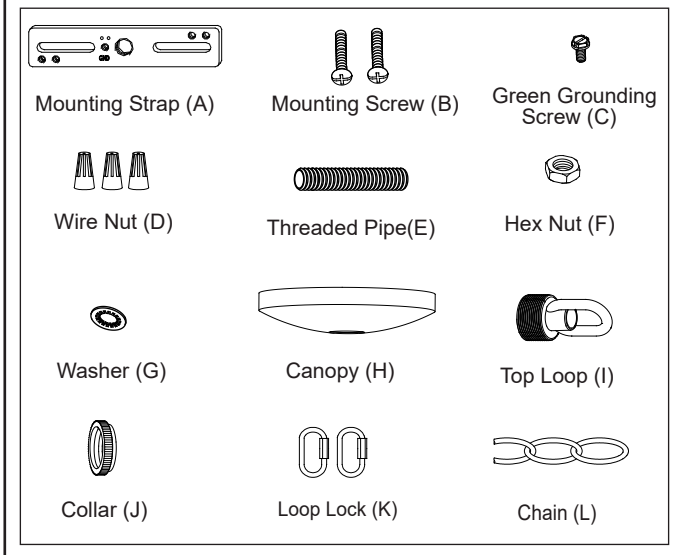

Installation Steps

Turn off the power at fuse or circuit box

1. Attach the threaded pipe to the mounting strap, and then secure it with a washer and a hex nut.
2. Attach mounting strap to the outlet box using two mounting screws.
3. Secure the top loop to the threaded pipe.
4. Inserting four pillars into holes of bottom metal frame, secure them with four bottom finials.
NOTE: The end of pillar with short threaded threads should be directed to the bottom metal frame.
5. Insert four folded metal plates to corners of bottom metal frame.

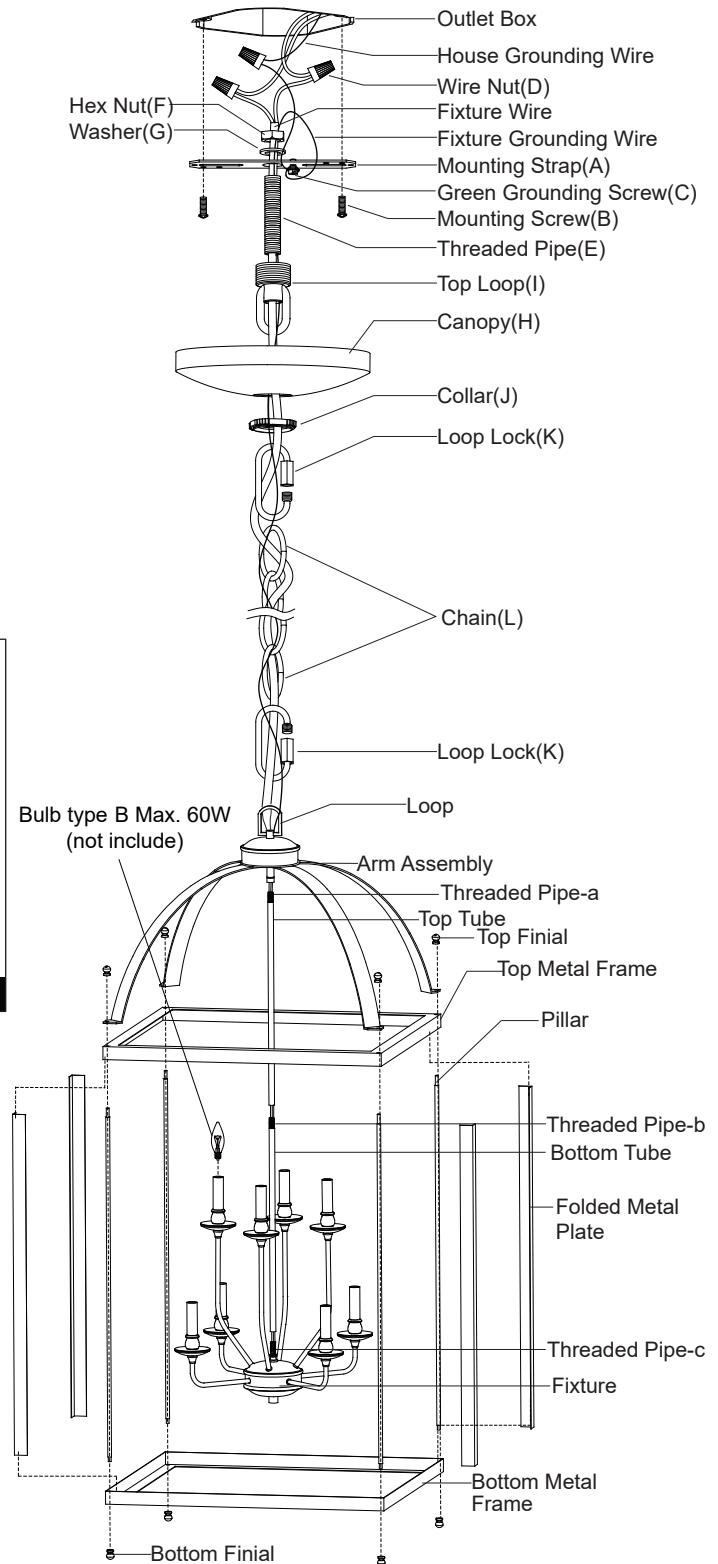

6. Attach the top metal frame to the ends of four folded metal plates by threading four pillars through the top metal frame, then install the remainder.
7. Thread the fixture wire through the arm assembly.
8. Adjust the arms according to the picture on the package.
NOTE: Make sure the narrow side of loop aligns midplane which consists of two near arms as possible. (See Fig.2)
9. Attach the adjusted arm assembly to top metal frame by threading four pillars through the holes of arms, secure them with four top finials, using a flathead screwdriver if necessary (not included).
10. Tube connections:
 - a. Secure the bottom tube onto fixture using the threaded pipe-c.
 - b. Secure the top tube onto the bottom tube using the threaded pipe-b.
 - c. Secure the top tube to arm assembly using the threaded pipe-a.**NOTE: Adjust the fixture direction in metal frame as desired when install the fixture.**
11. Connect the chain:
 - Determine needed length of chain to achieve desired fixture height. (To remove excess chain section, use pliers to bend link open.)
 - Weave the fixture wires and fixture grounding wire through the chain, collar and canopy.
12. Connect one end of the chain to the loop using a loop lock.
13. Connect the other end of the chain to top loop by using the other loop lock.
14. Thread the fixture wire and fixture grounding wire through the top loop, threaded pipe and mounting strap.
15. Pull out the source wires from the outlet box. Make wire connections using wire nuts as follows:
 - Connect the smooth-coated wire (marked) from the fixture to the black wire from the power source.
 - Connect the ribbed-coated wire (unmarked) from the fixture to the white wire from the power source.
 - Attach the fixture grounding wire to the mounting strap with the green grounding screw, and then connect it to the house grounding wire with a wire nut.Carefully put the wires back into the outlet box.
16. Attach the canopy to the mounting strap by inserting the top loop, and then secure it with the collar.
17. Install eight bulbs (not included). Check relamping label at socket area or packaging for maximum allowed wattage.

Turn on the power at fuse or circuit box

The following parts are available for re-order if damaged or missing.

Spare Parts List:

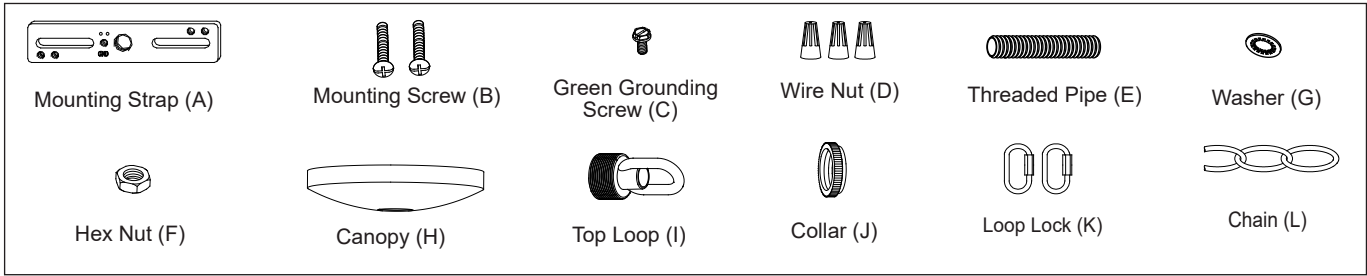

Assembly Kit
5648MM (1 SET)

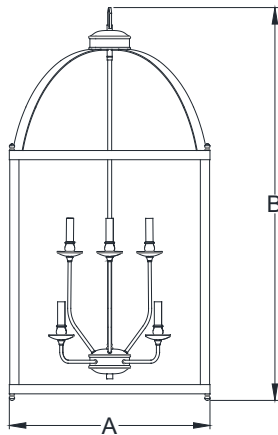

A: 24"

B: 47"

1 Year Warranty

Vaxcel warrants all of our products against defects in workmanship and finishes for one year following the date of shipment.

Exclusions: This warranty does not include the failure of products from extreme acts of nature; environmental conditions not suited for the products intended use; operation in temperatures outside of the range specified in the instruction manual; usage with improper power supply, power surges or dips. For coastal locations, some corrosion is considered normal for the environment.

Vaxcel reserves the right to repair, replace or issue a credit for any properly installed product, provided it is returned per RMA instruction. This warranty is limited to the cost of the product only and does not extend to transportation, installation or replacement costs.

How can warranty service be obtained?

info@vaxcel.com
1-800-482-9235