

ASSEMBLY AND INSTALLATION INSTRUCTIONS

P33057NS

WARNING: TO AVOID RISK OF ELECTRICAL SHOCK, BE SURE TO SHUT OFF POWER BEFORE INSTALLING OR SERVICING THIS FIXTURE.

NOTES: 1. Before installing, consult local electrical codes for wiring and grounding requirements.
2. READ AND SAVE THESE INSTRUCTIONS.

Hardware Package(inculded):

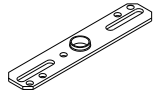

Mounting Strap (A)



Mounting Screw (B)



Wire Nut (C)

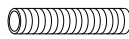

Threaded Pipe (D)



Green Grounding Screw (E)



Hex Nut (F)



Washer (G)



Finial (H)

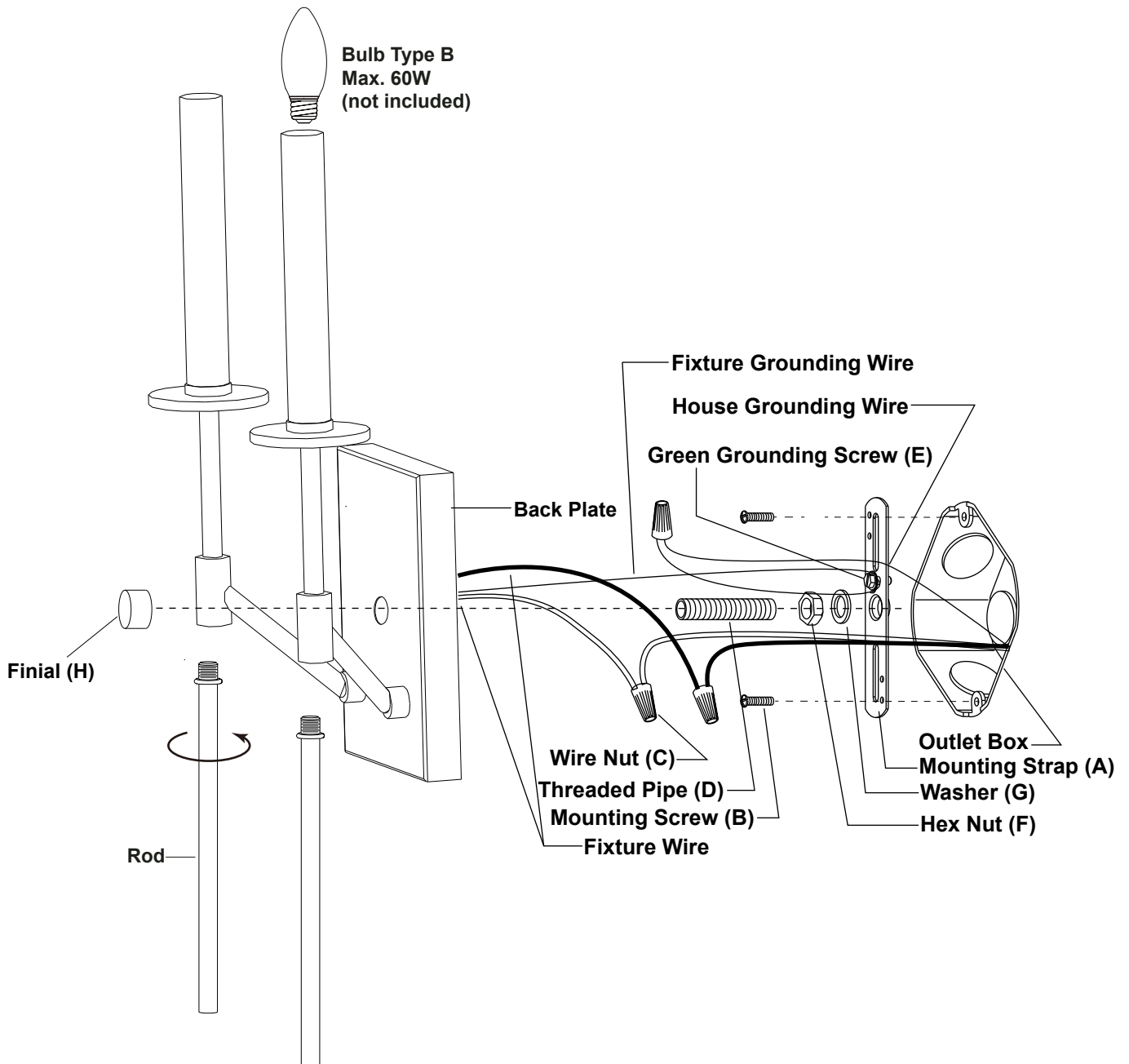

Installation Steps

Turn off the power at fuse or circuit box

1. Secure two rods into the couplings of the light.
2. Attach the threaded pipe to the mounting strap, and then secure it with a washer and a hex nut.
3. Attach the mounting plate to the outlet box by using two mounting screws.
4. Pull out the source wires from the outlet box. Make wire connections using wire nuts as follows:
 - Connect the hot wire (usually black insulation) from the fixture to the black wire from the power source.
 - Connect the neutral wire (usually white insulation) from the fixture to the white wire from the power source.
 - Attach the fixture grounding wire (usually green insulation or bare wire) to the mounting plate with the green grounding screw, and then connect it to the house grounding wire with the wire nut.Carefully put the wires back into the outlet box.
5. Attach the back plate to the mounting plate by inserting the threaded pipe, then secure it with the finial.
6. Install bulbs (not included). Check relamping label at socket area or packaging for maximum allowed wattage.

Turn on the power at fuse or circuit box

The following parts are available for re-order if damaged or missing.

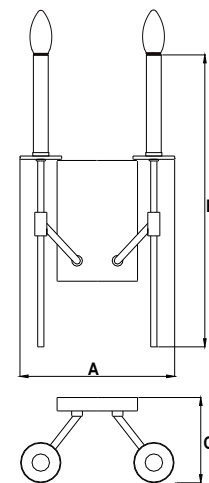
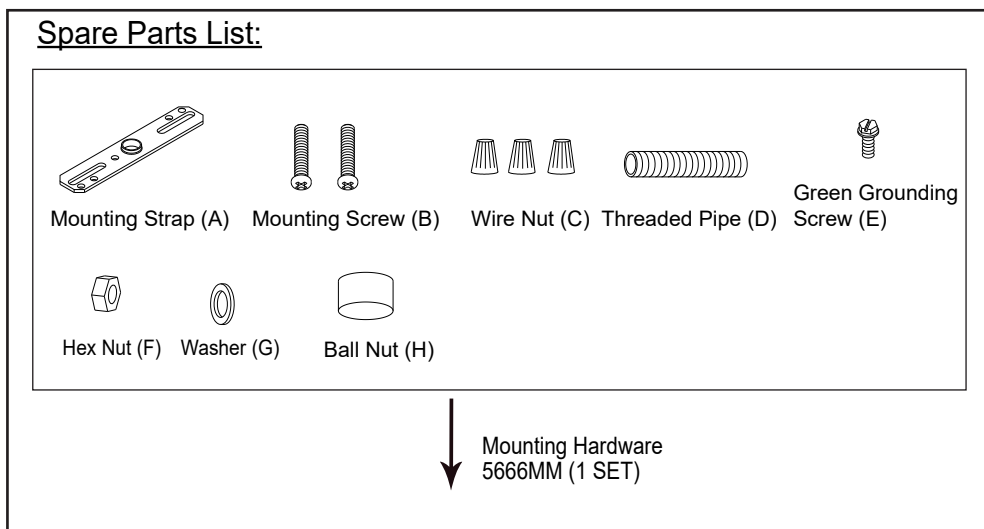

A: 9.5"
B: 17"
C: 5"

1 Year Warranty

Vaxcel warrants all of our products against defects in workmanship and finishes for one year following the date of shipment.

Exclusions: This warranty does not include the failure of products from extreme acts of nature; environmental conditions not suited for the products intended use; operation in temperatures outside of the range specified in the instruction manual; usage with improper power supply, power surges or dips. For coastal locations, some corrosion is considered normal for the environment.

Vaxcel reserves the right to repair, replace or issue a credit for any properly installed product, provided it is returned per RMA instruction. This warranty is limited to the cost of the product only and does not extend to transportation, installation or replacement costs.

How can warranty service be obtained?

info@vaxcel.com

1-800-482-9235